



Viale Europa, 12 - 20093 Cologno Monzese (MILANO) ITALY

Tel. 02-27302828 - Fax 02-25391518 - www.frer.it - frersale@frer.it - frerexport@frer.it

EDIZ. 4

EDIZ. 3

mod. UTDIN. DWG

EDIZ. 2

EDIZ. 1

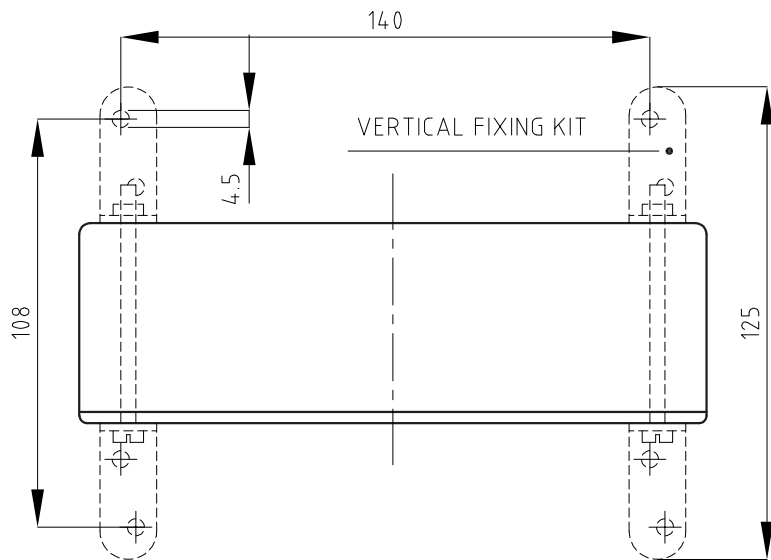
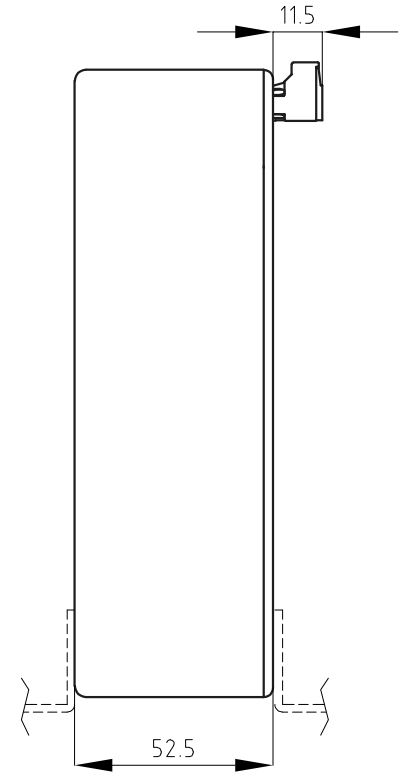
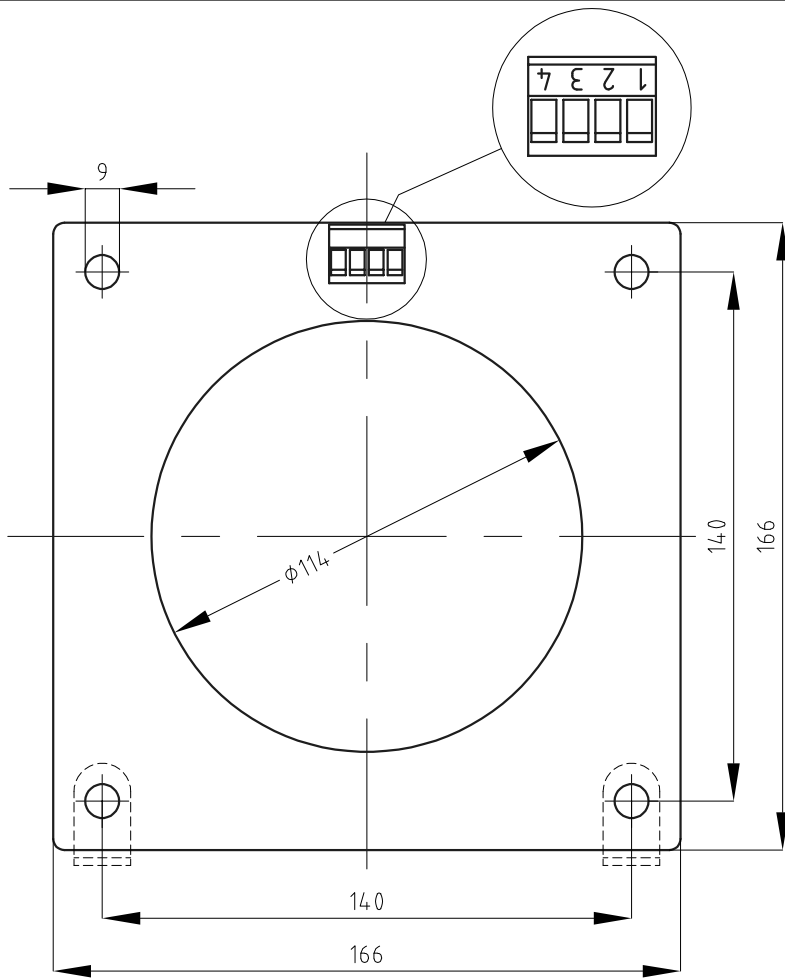

DIS./DES.

R.P.

EDIZ. 0

DATA/DATE  
20/12/24

DIMENSIONI D'INGOMBRO PER:  
OVERALL DIMENSIONS FOR:

SENSORE PER RELE' DIFFERENZIALE TIPO B COD. TDB110  
SENSOR FOR EARTH LEAKAGE RELAY TYPE B CODE TDB110

SCALA/SCALE

1:2

DOC.N.

UTDINI0423.0.DWG