



EDIZ.
4

EDIZ.
3

EDIZ.
2

EDIZ.
1

mod. UTDIN.DWG

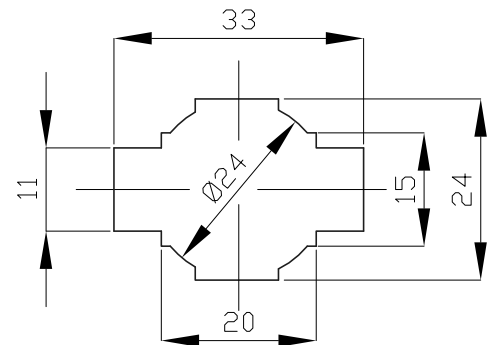
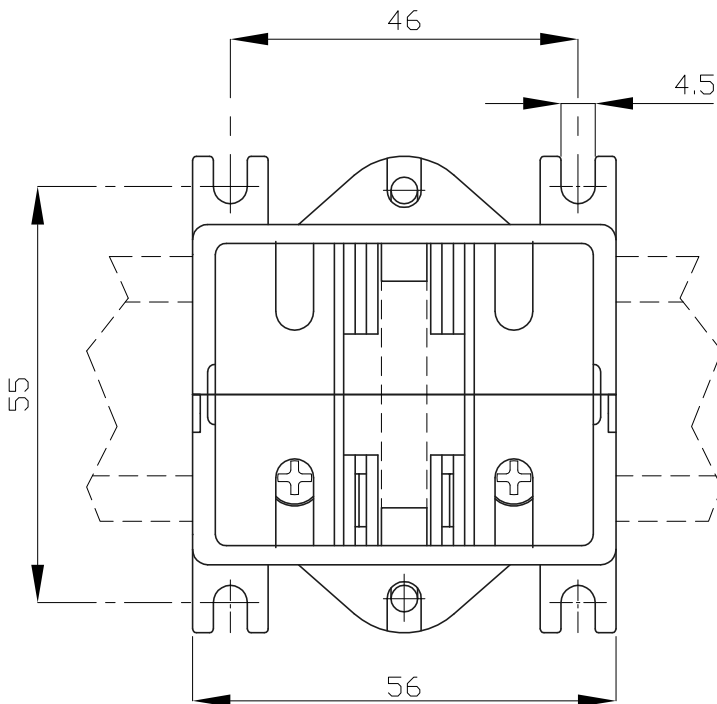
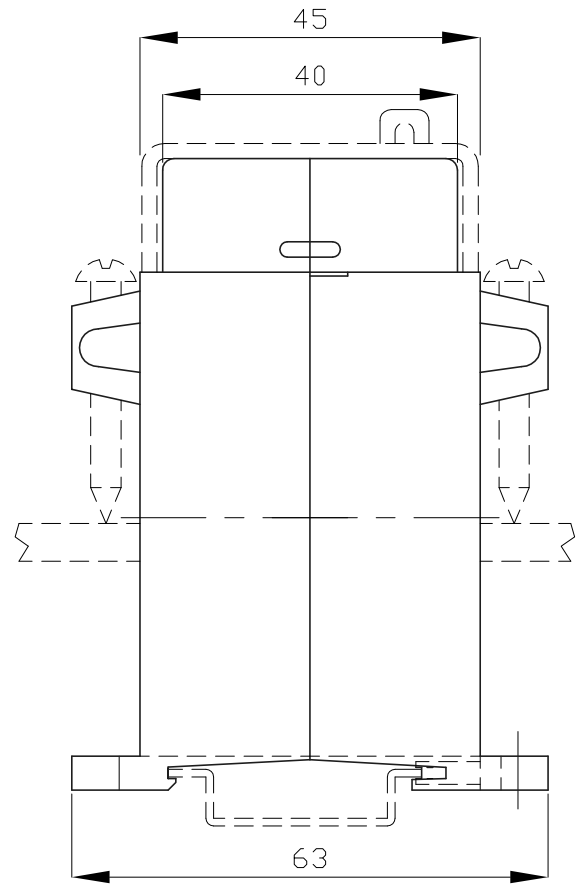
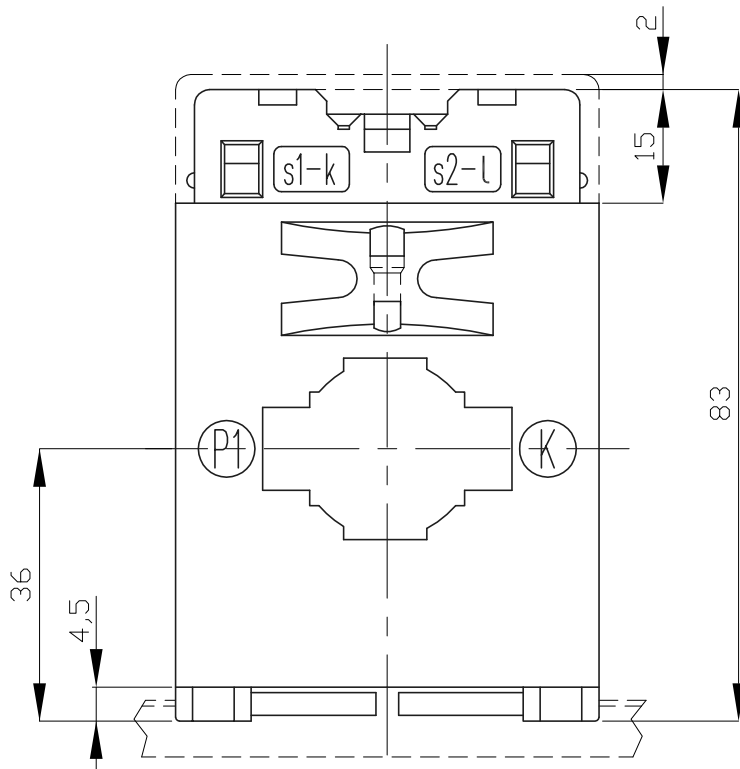

DIS.

R.P.

DIMENSIONI D'INGOMBRO PER:
OVERALL DIMENSIONS FOR:

SCALA

1:1

EDIZ.

DATA

0

14.7.95

TRASFORMATORE AMPEROMETRICO cod.1TAC032...
CURRENT TRANSFORMER cod. 1TAC032...

DOC.N.

UTDINI0220.0.DWG